

 **TEREX** | FINLAY

# TRACKED MOBILE HEAVY DUTY SCREEN



**883+**

**WORKS FOR YOU.™**

# 883+

The fourth generation Terex Finlay 883+ has been developed as a high capacity and versatile heavy duty scalper to work in primary and secondary screening applications such as quarry and mining, iron ore, construction demolition waste, sand, gravel, compost, top soil and coal.

The plant has the capacity to process at a rate of up to 600 tonnes per hour and can be fed either by a tracked mobile crusher, shovel or an excavator.

The machine is available with dual power technology giving flexibility to be powered by an external power supply or the standard on-board engine.

## Features:

- ▶ Modular configuration screen box with 4.8m x 1.5m (16' x 5') top deck and 4.8m x 1.5m (16' x 5') bottom deck screen.
- ▶ Each on board discharge conveyor is powered by a separate hydraulic circuit as standard.
- ▶ Width of fines conveyor is now 900mm (36") as standard.
- ▶ The banana profile and increased area of the new bottom deck maximizes screening of fines material.
- ▶ Screen box discharge end can be hydraulically raised 500mm to facilitate efficient and easy media access and changing.
- ▶ Fully reversible side conveyors as standard, which offers ultimate flexibility to the customer depending on their specific requirements.

## STANDARD FEATURES

### ENGINE:

Tier 3 Equivalent Caterpillar C4.4 - 4 cylinder diesel engine developing 83kW (111.3hp) 1800 RPM

Stage 3A Caterpillar C4.4 97kW Constant Speed Engine- 4 cylinder diesel engine developing 98kW (131hp) 1800 RPM - Europe Only

Tier 3 Equivalent Caterpillar C4.4 - 4 cylinder diesel engine developing 97kW (130hp) @ 1800rpm

Tier 4F / Stage IV - Caterpillar C4.4 - 4 cylinder diesel engine developing 82kW (110hp) @ 1800 RPM

### FEEDER:

Abbrasion Resistant plate steel pan apron feeder with heavy duty chain drive

Fixed Hopper

Remote start stop of pan feeder

### SCREENBOX:

Modular configuration screen box

Hydraulic raise for mesh changing (500mm)

Both top and bottom decks 4.8m x 1.53m (16' x 5')

No mesh included for any deck (but all mesh fitting parts included as standard)

### OVERSIZE CONVEYOR:

Belt Width: 1.2m (48") chevron belt & skirting

### MIDDLEGRADE CONVEYOR:

Belt Width: 800mm (32") chevron belt with variable speed & thumper roller

### FINES CONVEYOR:

Belt Width: 900mm (36") Plain belt with variable speed and belt scraper

Separate hydraulic drive on all conveyors

### ELECTRICAL:

Emergency Stops (4 nr)

Control operation of tracks via hand held-set with 5m connection lead

T-Link Telemetry System fitted c/w 3 years data subscription

## HOPPER / FEEDER

- ▶ Hopper Capacity: 7m<sup>3</sup> (9.16yd<sup>3</sup>)
- ▶ Feed height: 3.69m (12' 1")
- ▶ Feed in width: 2.6m (8' 7")
- ▶ Drive: Hydraulic variable speed drive (0-25mph) via high torque motor
- ▶ Apron feeder dimensions: 1m wide x 3.81m (40" x 12' 6")
- ▶ Abrasion Resistant steel pan apron feeder mounted with wide mouth opening

## TRANSFER CONVEYOR

- ▶ Belt width: 1.2m (48")
- ▶ Belt spec: 3 ply Belt, EP 400
- ▶ Belt Speed: 77 m/min (253 ft/min)
- ▶ Conveyor fully skirted

## POWERUNIT

- ▶ Tier 3 Equivalent: Caterpillar C4.4  
Engine Power: 83kW (111.3hp)  
Engine Speed: 1800 rpm
- ▶ Stage IIIA Constant Speed: Caterpillar C4.4  
Engine Power: 98kW (131hp)  
Engine Speed: 1800 rpm
- ▶ Tier 4F / Stage IV : Caterpillar C4.4  
Engine Power: 82kW (110hp)  
Engine Speed: 1800 rpm

## FINES CONVEYOR

- ▶ Belt width: 900mm (36")
- ▶ Belt spec: plain belt
- ▶ Working Angle: 24° - 28°
- ▶ Rosta scraper on head drum
- ▶ Speed: variable speed, 127 m/min (417 ft/min) max belt speed
- ▶ Standard Discharge Height: 4m (13' 1") max
- ▶ Stockpile capacity: 95m<sup>3</sup> (124yd<sup>3</sup>) max
- ▶ Optional telescopic section
- ▶ Extended Discharge Height: 4.8m (15' 9")
- ▶ Stockpile capacity: 164.5m<sup>3</sup> (215yd<sup>3</sup>)

## UNDERCARRIAGE

- ▶ Shoe
- ▶ Sprocket
- ▶ Speed
- ▶ Grade
- ▶ Raking



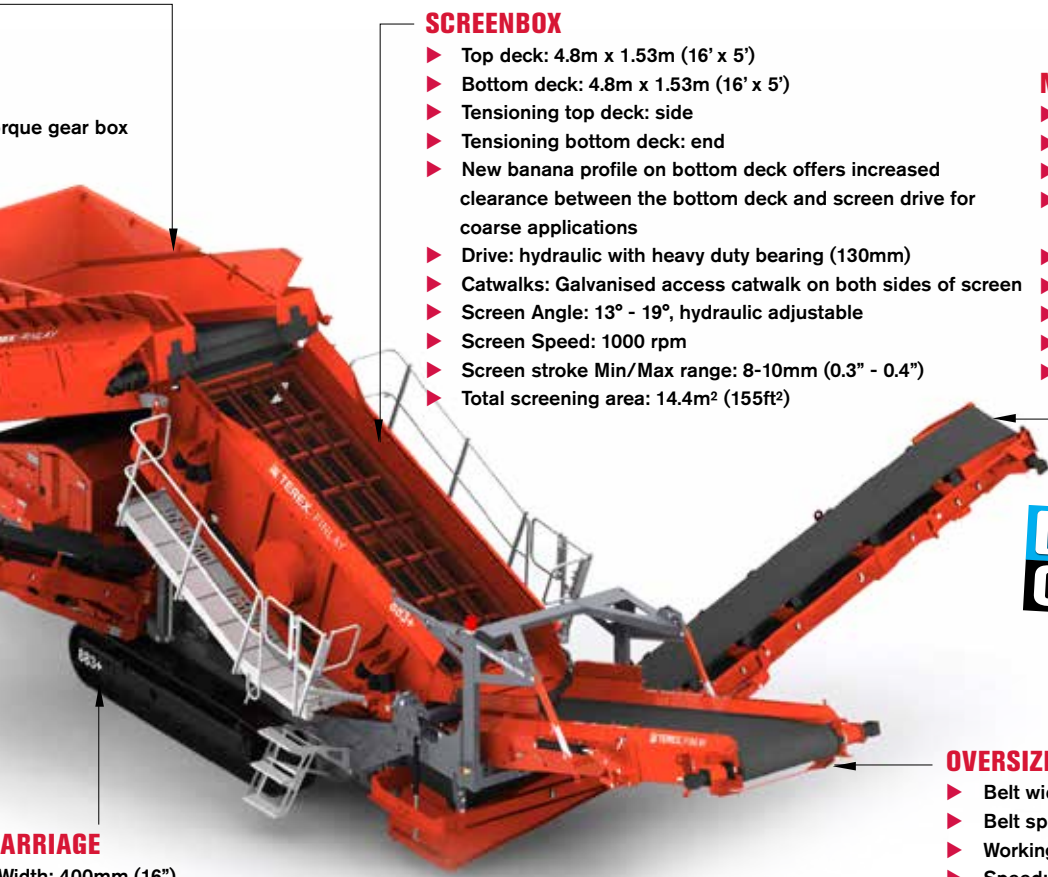

**SCREENBOX**

- ▶ Top deck: 4.8m x 1.53m (16' x 5')
- ▶ Bottom deck: 4.8m x 1.53m (16' x 5')
- ▶ Tensioning top deck: side
- ▶ Tensioning bottom deck: end
- ▶ New banana profile on bottom deck offers increased clearance between the bottom deck and screen drive for coarse applications
- ▶ Drive: hydraulic with heavy duty bearing (130mm)
- ▶ Catwalks: Galvanised access catwalk on both sides of screen
- ▶ Screen Angle: 13° - 19°, hydraulic adjustable
- ▶ Screen Speed: 1000 rpm
- ▶ Screen stroke Min/Max range: 8-10mm (0.3" - 0.4")
- ▶ Total screening area: 14.4m<sup>2</sup> (155ft<sup>2</sup>)

**MIDGRADE CONVEYOR**

- ▶ Belt width: 800mm (32")
- ▶ Belt spec: chevron belt
- ▶ Working Angle: 22° - 26° max
- ▶ Speed: variable speed 127m/min (417 ft/min) max belt speed
- ▶ Standard Discharge Height: 3.4m (11' 2") max
- ▶ Stockpile capacity: 58m<sup>3</sup> (76yd<sup>3</sup>) max
- ▶ Optional telescopic section
- ▶ Extended Discharge Height: 4.1m (13' 5")
- ▶ Stockpile capacity: 102.5m<sup>3</sup> (134.1yd<sup>3</sup>)

**DUAL POWER**  
OPTION AVAILABLE

**ARRIAGE**

- Width: 400mm (16")
- Track Centres: Centres: 3.28m (10' 9")
- Speed: 0.8kph
- Stability: 24.8°
- Working Angle: 11° min

**OVERSIZE CONVEYOR**

- ▶ Belt width: 1.2m (48")
- ▶ Belt spec: 3 ply Belt, EP 400
- ▶ Working Angle: 18° - 24°, hydraulic adjust
- ▶ Speed: Variable speed, 53 m/min max belt speed
- ▶ Impact bars 2/3 Length of Conveyor (Full length optional)
- ▶ Steel skirted full length of conveyor
- ▶ Discharge Height: 3.6m (11' 10")
- ▶ Stockpile capacity: 70m<sup>3</sup> (91yd<sup>3</sup>) max



**Transport Dimensions**

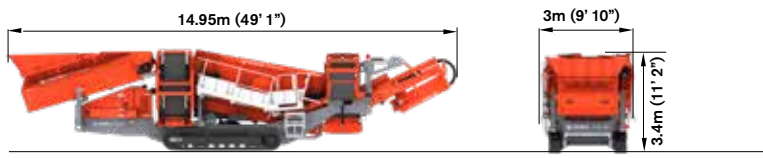

**Working Dimensions**

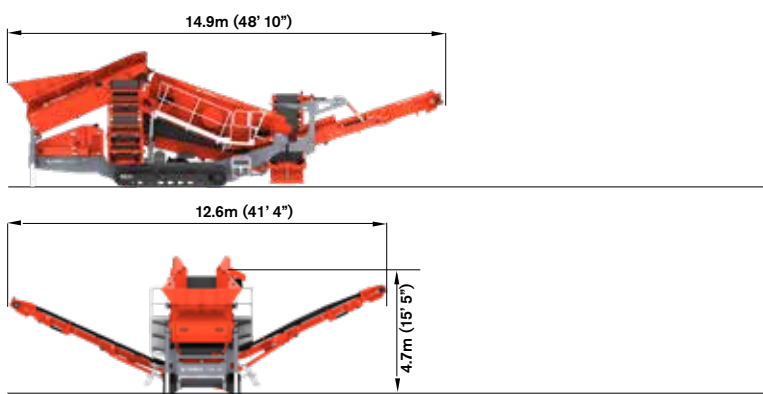

Machine Weight: \* 31,000kg (68,340lbs)  
\* Standard Machine configuration

**WORKS FOR YOU.™**



# Tlink

## FLEET MANAGEMENT SYSTEM

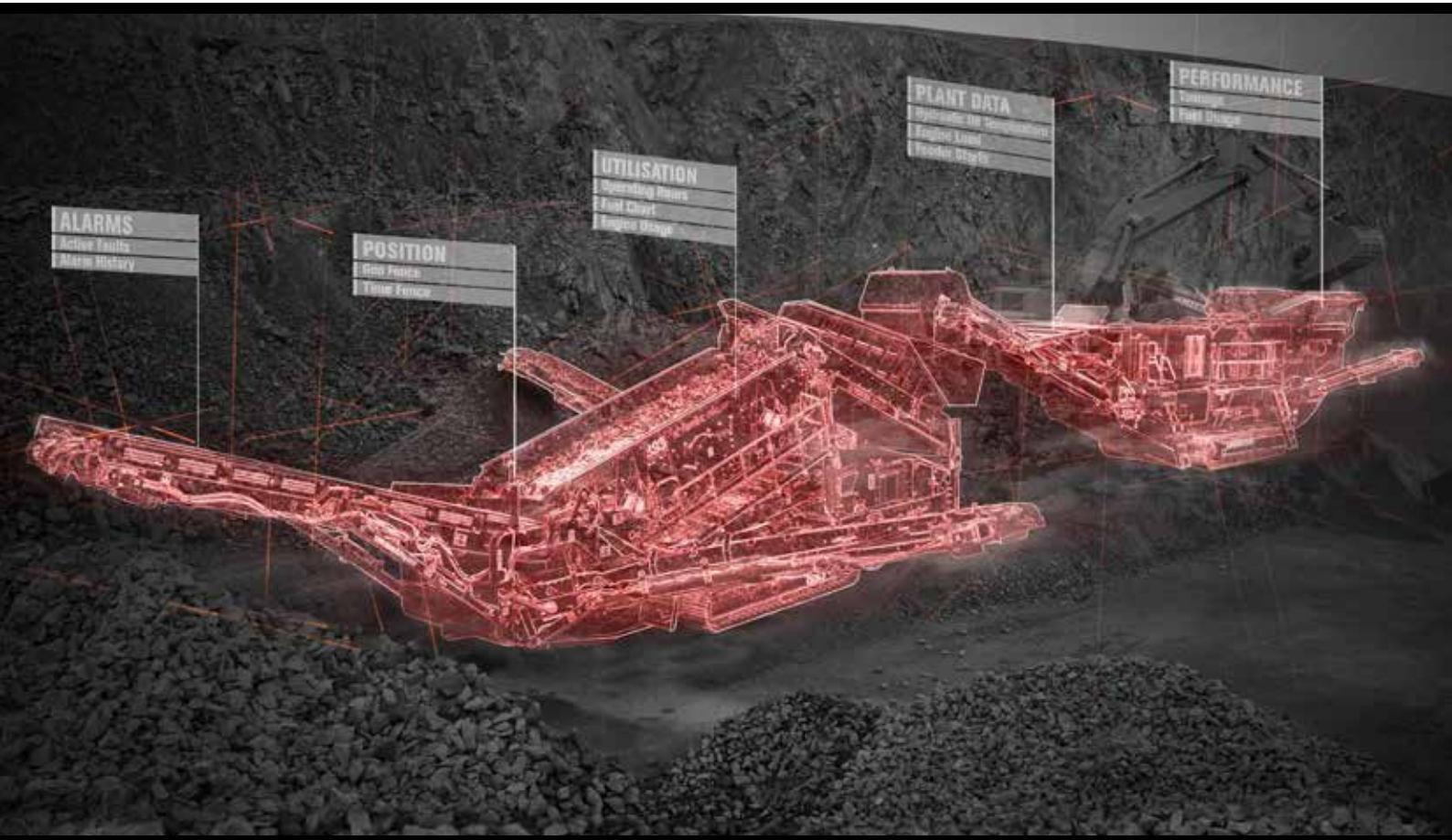

**FOR FURTHER INFORMATION CONTACT:**

**E. [finlay.tlink@terex.com](mailto:finlay.tlink@terex.com)**

Follow Us:



**[www.terexfinlay.com](http://www.terexfinlay.com)**

Effective July 2018. Product specifications and prices are subject to change without notice or obligation. The photographs and/or drawings in this document are for illustrative purposes only. Refer to the appropriate Operator's Manual for instructions on the proper use of this equipment. Failure to follow the appropriate Operator's Manual when using our equipment or to otherwise act irresponsibly may result in serious injury or death. The only warranty applicable to our equipment is the standard written warranty applicable to the particular product and sale and Terex USA LTD. makes no other warranty, express or implied. Products and services listed may be trademarks, service marks or trade-names of Terex Corporation and/or its subsidiaries in the USA and other countries. All rights are reserved. Terex® is a registered trademark of Terex Corporation in the USA and many other countries. Copyright 2010 Terex USA Ltd.

 **TEREX** | FINLAY

**WORKS FOR YOU.™**