

WORKING

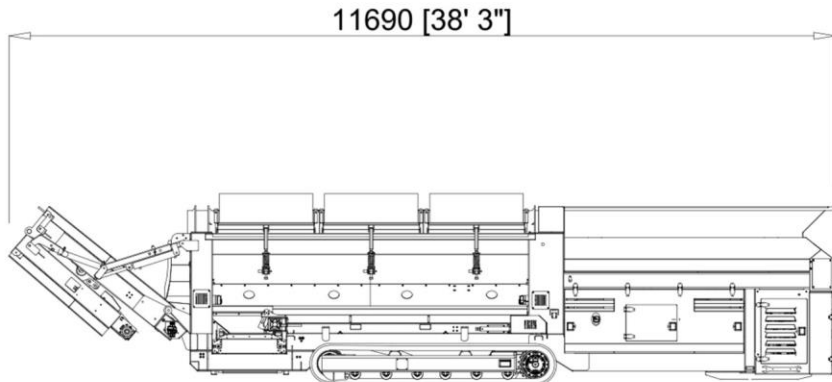

TRANSPORT

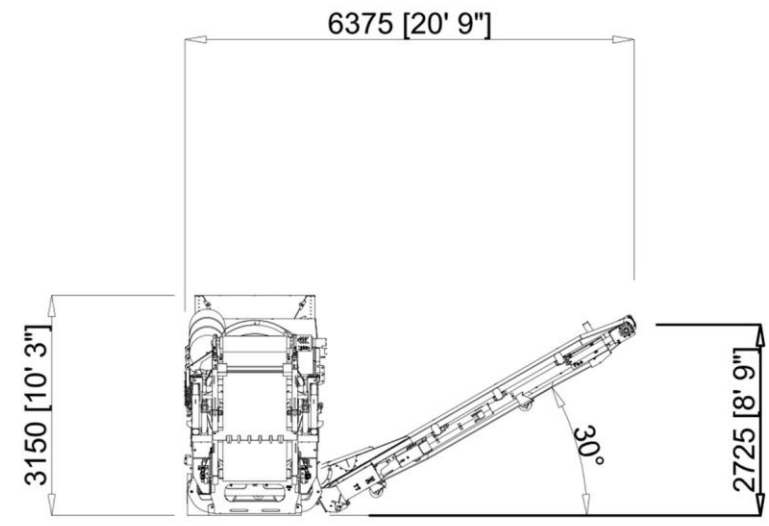
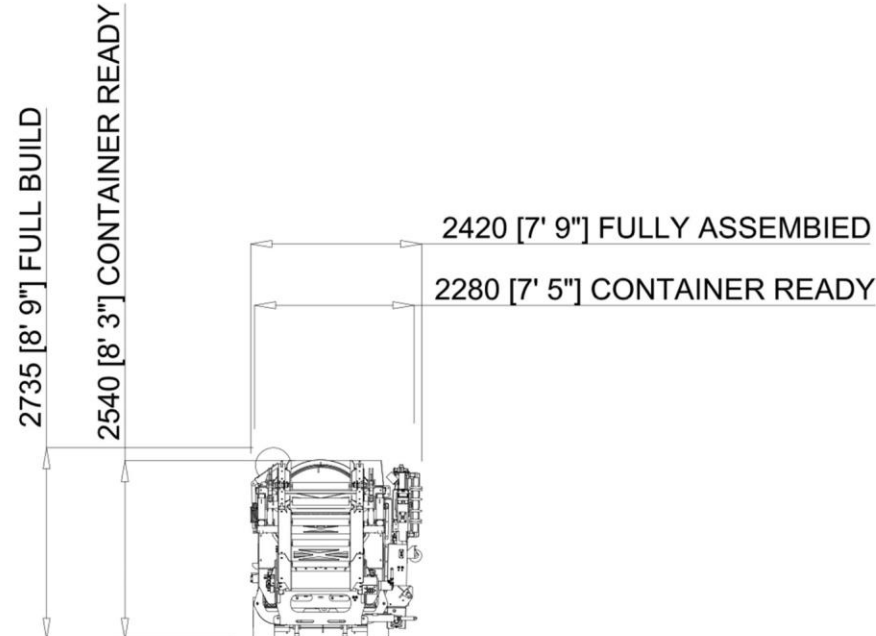

TS516 TROMMEL SCREEN

HOPPER

Width	1.47m (4'8")
Length	3.72m (12'2")
Max Volume with extensions	4m ³ (5.2yd ³)

FEEDER BELT

Width	900mm (35")
Type	Plain Belt
Control	Variable Speed

DRUM

Length	5.15m (16'9")
Diameter	1.37m (4'5")
Angle	0-5°

COLLECTION BELT

Width	900mm (35")
Control	Variable Speed

TRANSFER BELT

Width	650mm (25")
Control	Variable Speed

FINES BELT

Width	800mm (31")
Discharge Height	2.72m (8'9")
Control	Variable Speed

OVERSIZE (TAIL) BELT

Width	900mm (35")
Discharge Height	2.47m (8'1")
Control	Variable Speed

POWER PACK

Type 3a	JCB Dieselmax 444 63kW (84HP)
Type 3b	JCB Ecomax 68kW (91HP)
Diesel Tank	260L (57 gallon / 68 US gallon)
Hydraulic Tank	345L (75 gallon / 91 US gallon)

OPTIONS

1. Radio remote tipping grid
2. Punch plate screens
3. Radio remote control

TRACKS

Width	300mm (12")
Speed	1km/h

PERFORMANCE

Max Feed Size	300mm (12")
Max Screen Size	60mm (3")
Capacity	Up to 150tph

WORKING DIMENSIONS

Without Grid

Length	13.37m (43'8")
Width	6.37m (20'9")
Height	3.15m (10'3")

TRANSPORT DIMENSIONS

Without Grid

Length	11.69m (38'3")
Width Max	2.42m (7'9")
Width Min	2.28m (7'5")
Height Max	2.73m (8'9")
Height Min	2.54m (8'3")

GENERAL

Weight	14,500kgs / 16 US TON (32000lbs)
--------	----------------------------------

ScreenpodTM
Design & Manufacturing

Copyright 2017 by Crushers4Sale Ltd. All rights reserved

This document or any part thereof must not be reproduced without the permission of Crushers 4 Sale Ltd

Crushers4Sale